

Heavyduty Type

Pneumatic Shear Knifeholder

MT-A660

MT-A660 the pneumatic shear-type knifeholder equips two sets of the manual valve which able to individually or be linked to control the downstroke and sidestroke. Our patented knife-holder body is made of high-strength 6061 aluminum alloy, can provide stable downforce pressure by three-cylinder robust design, reaching the perfect slitting effect. MT-A660 can well-handle the adjustment of the cant angle for the different material path direction, also strengthen the structure to ensure the consistency of the slitting quality.

With high rigidity knife-holder and the 150mm blade, MT-A660 knife-holder is ideally suited for paper, plastic film, non-woven fibers, and others converting industry material.

» Feature

- Min slitting width 65mm
- Patented self flow control
- Micro down stroke adjustment
- Individual control valve
- Cant angle adjustment
- Patented structure design

» Specification

- Min. slitting width : 65mm
- Max. slitting speed : 1000M/min ⁽¹⁾
- Down stroke range : 0~25mm
- Side contact range : 0~3mm
- Top blade dia. : ϕ 150mm
- Guide-bar : GB01/GB02/GB04

(1) Max slitting speed depends on different material and the condition will be char



MT-A660 Dimension drawing

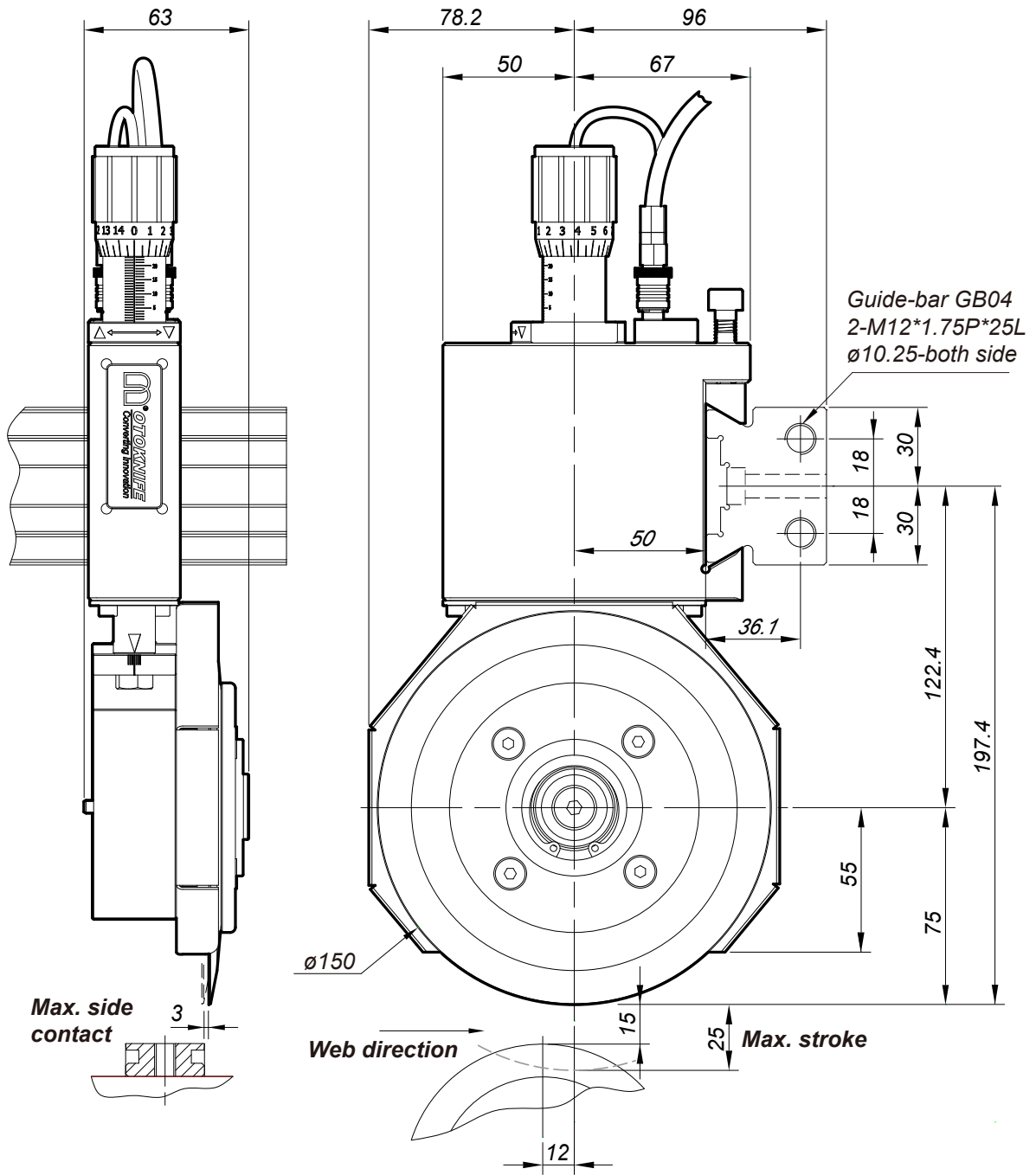

Blade dimension drawing

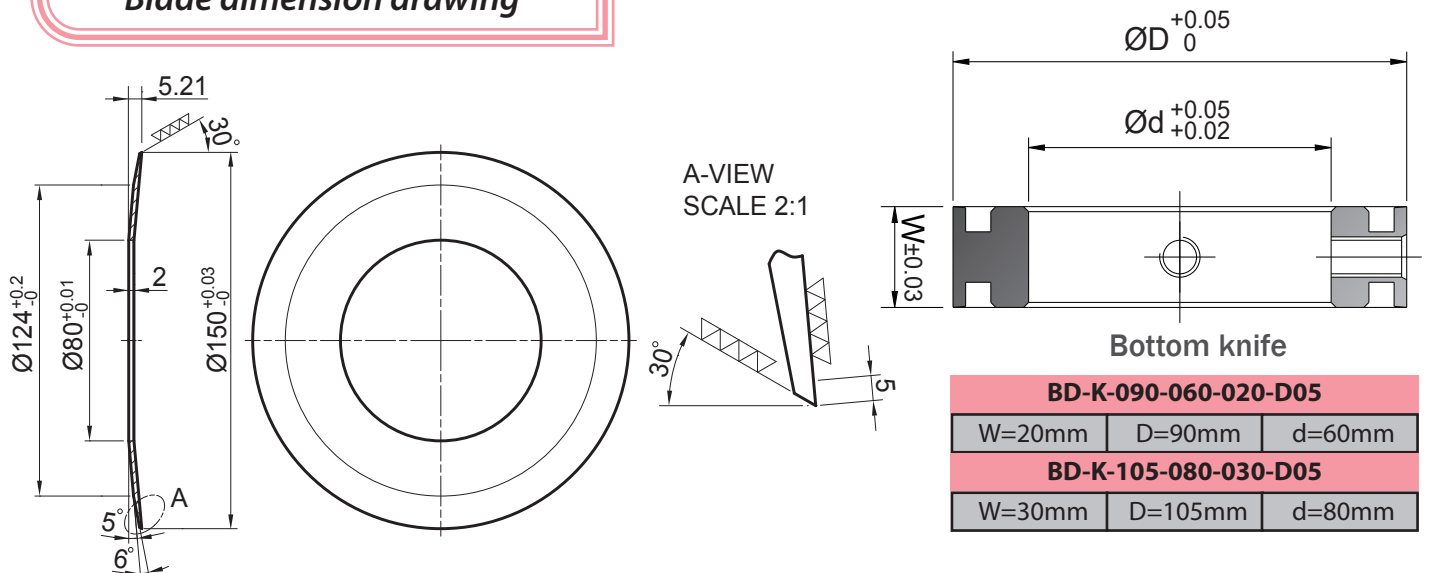

Different web path arrange

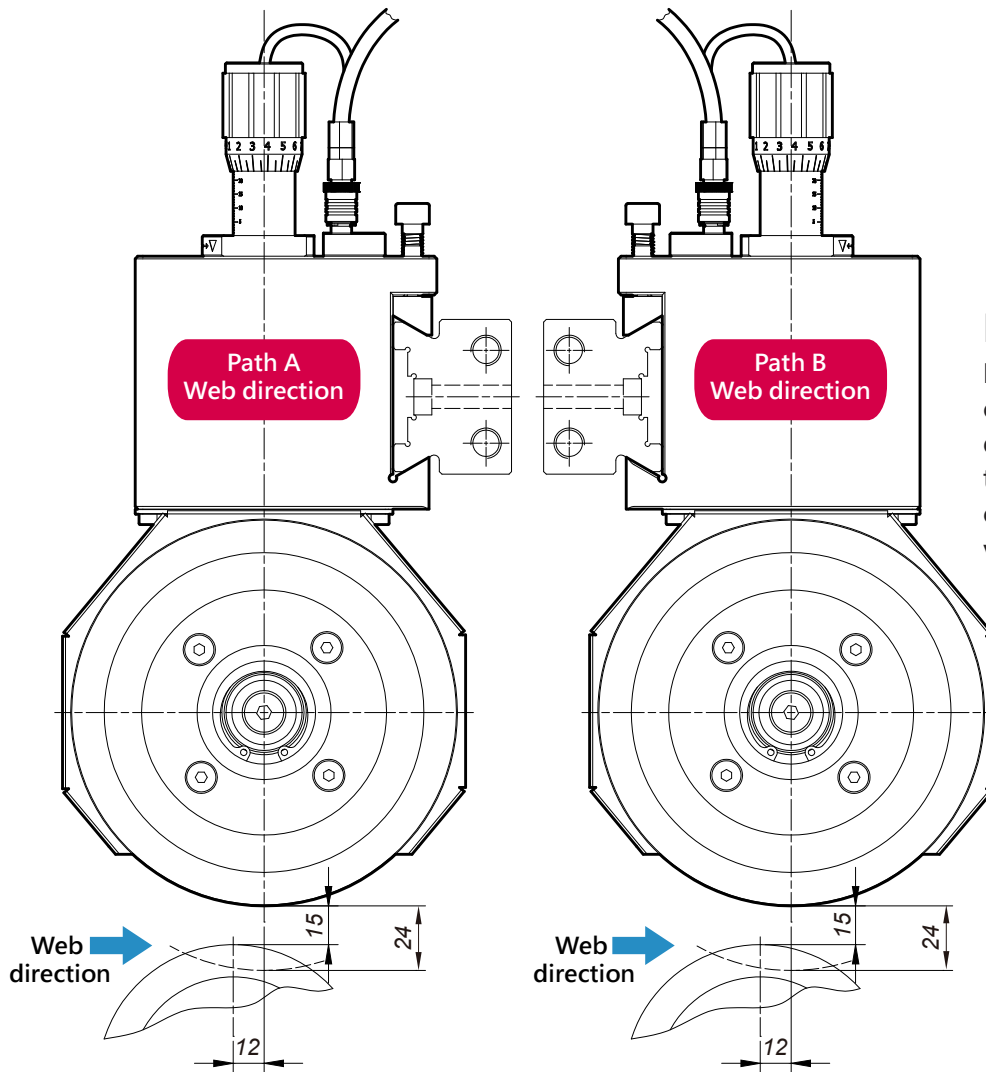

Different Web Path

Easily changeable cant angle can is for different web path direction application, in order to obtain better slitting effect corrcet cant angle setup is very important!!

Knife-holder direction arrange

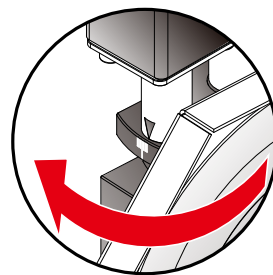
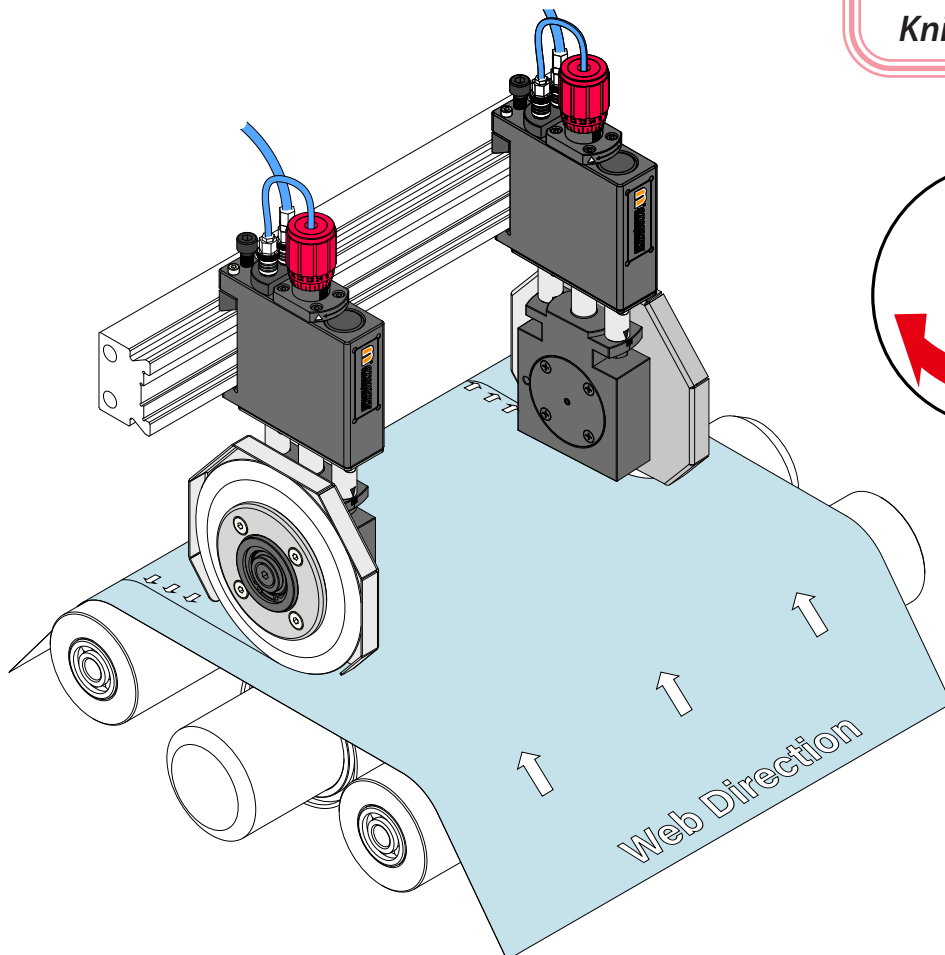

Path A

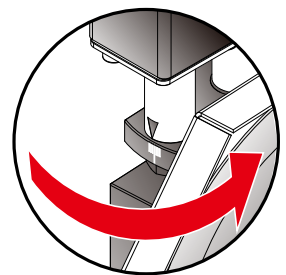

Path B

Cant angle adjust

For different web path application now is more easily to adjust. Unscrew angle plate and rotate bottom knifeholder for different web path direction and to get better efficiency result.

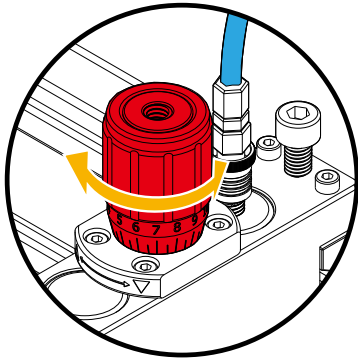

Depth adjust

Using depth adjust screw can easily control down stroke overlap distance between top and bottom blade, it is helpful for overlap compensation when blade wear.

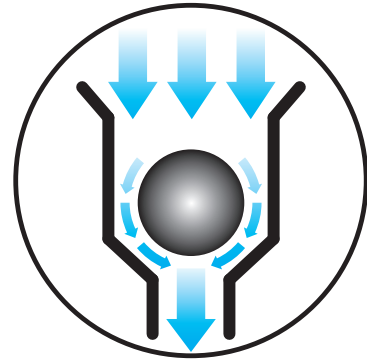

Internal air flow control

Patent design with internal air flow control, you can directly connect air source without air throttle valve and never worry too much air flow to damage blade!!

Individual valve control

More convenient for down stroke and side contact individual valve control, it can be operation under automatic action or separate when arrange position.

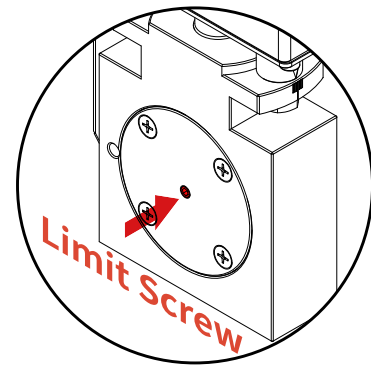
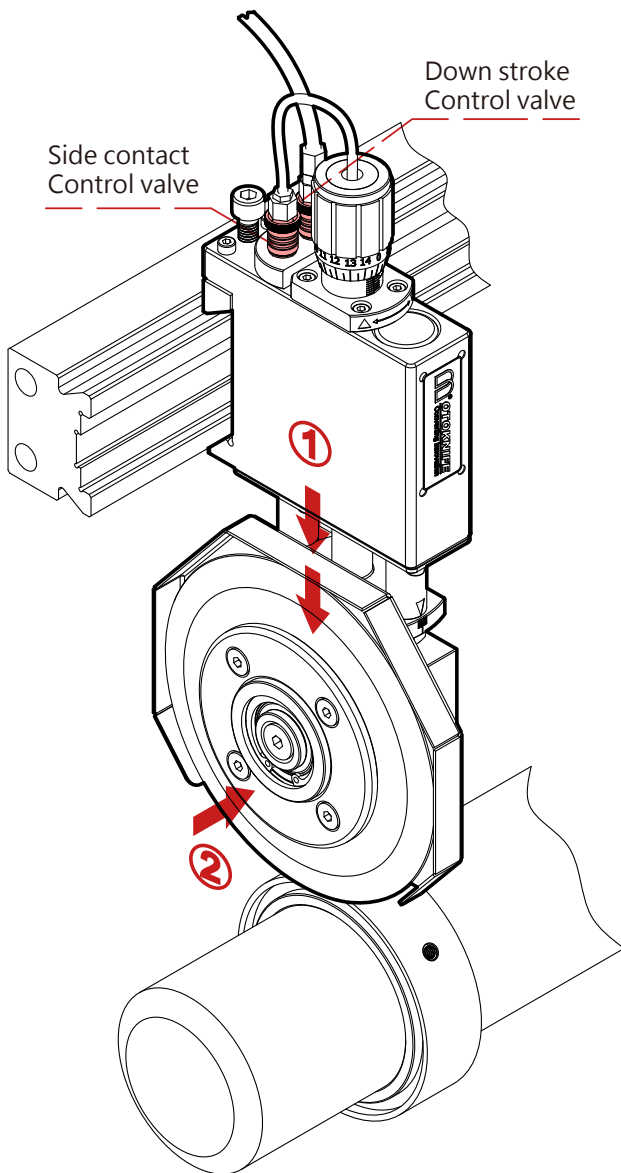

Side contact limit

Behind the bottom knife-holder have limit screw can be adjust side contact stroke, proper side stroke setting will extend blade life time and getting better slitting edge.

Slitting Products Available:

Various Papers	kraft paper, silicone paper, releasing paper, decoration wall paper, masking paper, adhesive paper, thick paper board, corrugated carton paper, sand paper.
Various Plastic films	flexible laminated films, soft & rigid PVC films, BOPP, PET, PE, PS, LDPE, PLA, SBS, various adhesive tape...etc.
Cloth & fabrics	non-woven cloth, synthetic leather, natural cotton, mesh cloth, medical cloth, label cloth...etc.
Metal films	copper foil, aluminum foil.

MT-A660

MOTOKNIFE



MOTO, TAIWAN
32652 No.65 Lane 155, Xinjiang Rd.,
Yangmei District, Taoyuan City, Taiwan
TEL:+886-3-4753005
FAX:+886-3-4754797
E-mail:service@motoknife.com
http://www.motoknife.com

MOTO, CHINA
No.8 Zhang Jia Road, Huang Du Town,
JiaDing Area, Shanghai, China
TEL:+86-21-69596169
FAX:+86-21-69596163
E-mail:motokevin@126.com

